



## PC-08 Effects Controller



**ORDER CODE: CONT05**

**USER MANUAL**

[www.prolight.co.uk](http://www.prolight.co.uk)

## WARNING

**FOR YOUR OWN SAFETY, PLEASE READ THIS USER MANUAL CAREFULLY BEFORE YOUR INITIAL START-UP!**



### CAUTION!

**Keep this equipment away from rain, moisture and liquids.**



## SAFETY INSTRUCTIONS

Every person involved with the installation, operation & maintenance of this equipment should:

- Be competent
- Follow the instructions of this manual



**CAUTION! TAKE CARE USING THIS EQUIPMENT!  
HIGH VOLTAGE-RISK OF ELECTRIC SHOCK!!**



Before your initial start-up, please make sure that there is no damage caused during transportation. Should there be any, consult your dealer and do not use the equipment.

To maintain the equipment in good working condition and to ensure safe operation, it is necessary for the user to follow the safety instructions and warning notes written in this manual.

Please note that damages caused by user modifications to this equipment are not subject to warranty.

## IMPORTANT:

**The manufacturer will not accept liability for any resulting damages caused by the non-observance of this manual or any unauthorised modification to the equipment.**

- Never let the power-cable come into contact with other cables. Handle the power-cable and all mains voltage connections with particular caution!
- Never remove warning or informative labels from the equipment.
- Do not open the equipment and do not modify the equipment.
- Do not switch the equipment on and off in short intervals, as this will reduce the system's life.
- Only use the equipment indoors.
- Do not expose to flammable sources, liquids or gases.
- Do not carry the unit with only one handle. Always carry using both handles.
- Always disconnect the power from the mains when equipment is not in use or before cleaning! Only handle the power-cable by the plug. Never pull out the plug by pulling the power-cable.
- Make sure that the available voltage is between 220v/240v.
- Make sure that the power-cable is never crimped or damaged. Check the equipment and the power-cable periodically.
- If the equipment is dropped or damaged, disconnect the mains power supply immediately. Have a qualified engineer inspect the equipment before operating again.
- If the equipment has been exposed to drastic temperature fluctuation (e.g. after transportation), do not switch it on immediately. The arising condensation might damage the equipment. Leave the equipment switched off until it has reached room temperature.
- If your product fails to function correctly, discontinue use immediately. Pack the unit securely (preferably in the original packing material), and return it to your Prolight dealer for service.
- Only use fuses of same type and rating.
- Repairs, servicing and power connection must only be carried out by a qualified technician. **THIS UNIT CONTAINS NO USER SERVICEABLE PARTS.**
- **WARRANTY;** One year from date of purchase.

## OPERATING DETERMINATIONS

If this equipment is operated in any other way, than those described in this manual, the product may suffer damage and the warranty becomes void.

Incorrect operation may lead to danger e.g.: short-circuit, burns, electric shocks, lamp failure etc.

Do not endanger your own safety and the safety of others!

Incorrect installation or use can cause serious damage to people and property.

### Operation:

The unit has been designed to independently switch ON/OFF up to eight lighting fixtures via the power sockets at the rear. Simply plug each unit into the appropriate socket using the correct power plug and away you go!

For your protection the Effects controller has been fitted with a 15A circuit breaker which will disconnect the main power supply to the outputs should you either overload the unit or if there is a power surge. In such circumstances it is necessary to press the reset button to re-activate the power to the controller. Please turn off all 8 switches prior to pressing the reset button.

### Installation / Mounting:

This Controller may be used either seated on a level surface or mounted into an appropriate 19" (1U space required) rack cabinet. For reasons of safety it is best to secure the unit into a rack or a suitable mounting so that cables cannot be pulled out of the panel.

### Overview:

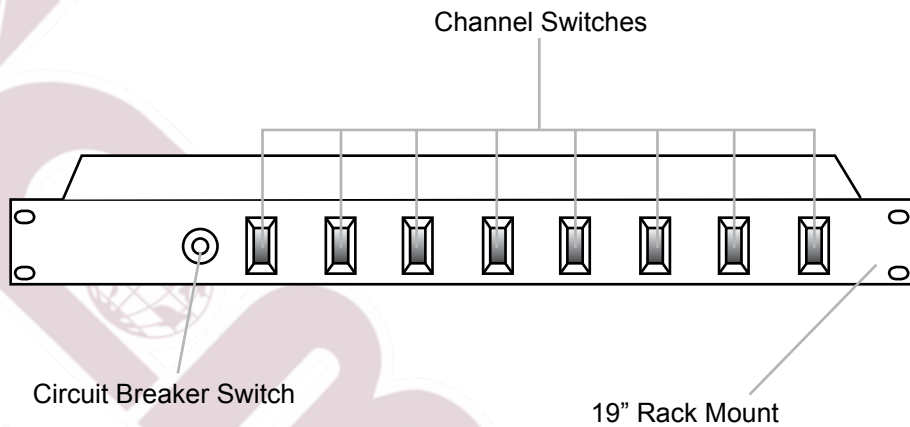

### Technical Specifications:

Power	230V~50Hz AC
Load Capacity	15A (with suitable connector) 13A (with UK mains plug)
Circuit Breaker	15A Reset switch
Power Outlets	8 x 230V (10A) 3-pin IEC female
Dimensions	483 x 102 x 45mm / 19in x 4in x 1.75in
Weight	2Kg